

REVISIONS			
REV.	DESCRIPTION	DATE	INIT
0	INITIAL RELEASE	08/12/15	MJS

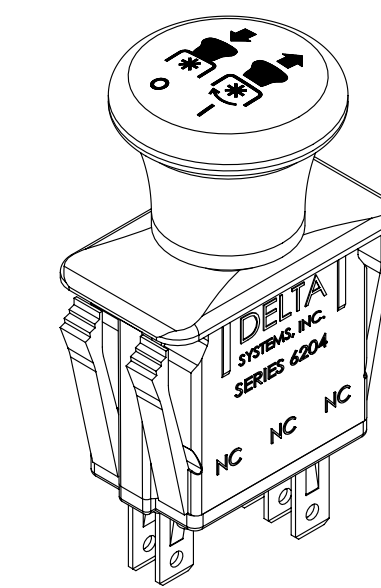

SNAP WINGS TO ACCOMMODATE SPECIFIC PANEL THICKNESSES OF;
 .055 [1.4] MAX. (WITH #972301 RETAINER RING)
 .085 [2.2] MAX. (WITH #972301 RETAINER RING)
 .105 [2.7] MAX.
 .135 [3.4] MAX.
 .165 [4.2] MAX.
 (NOTE 12)

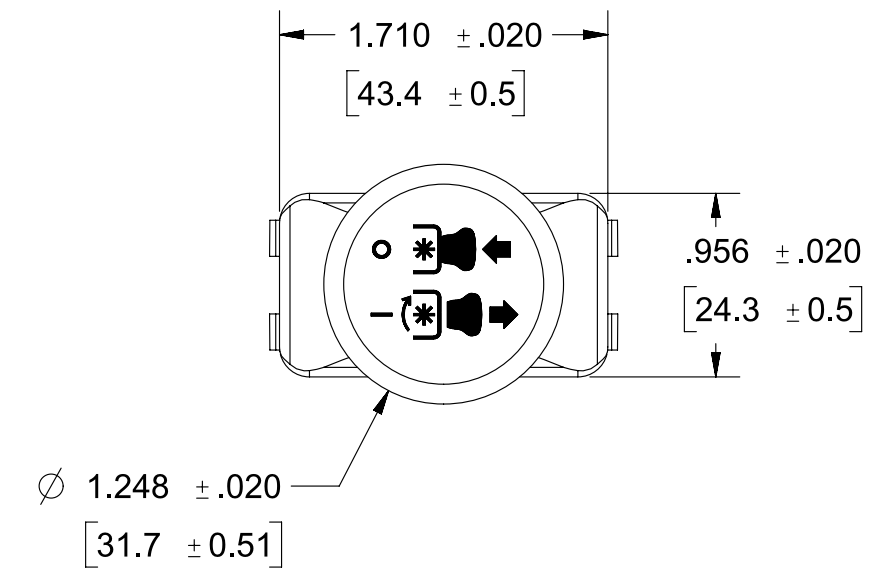
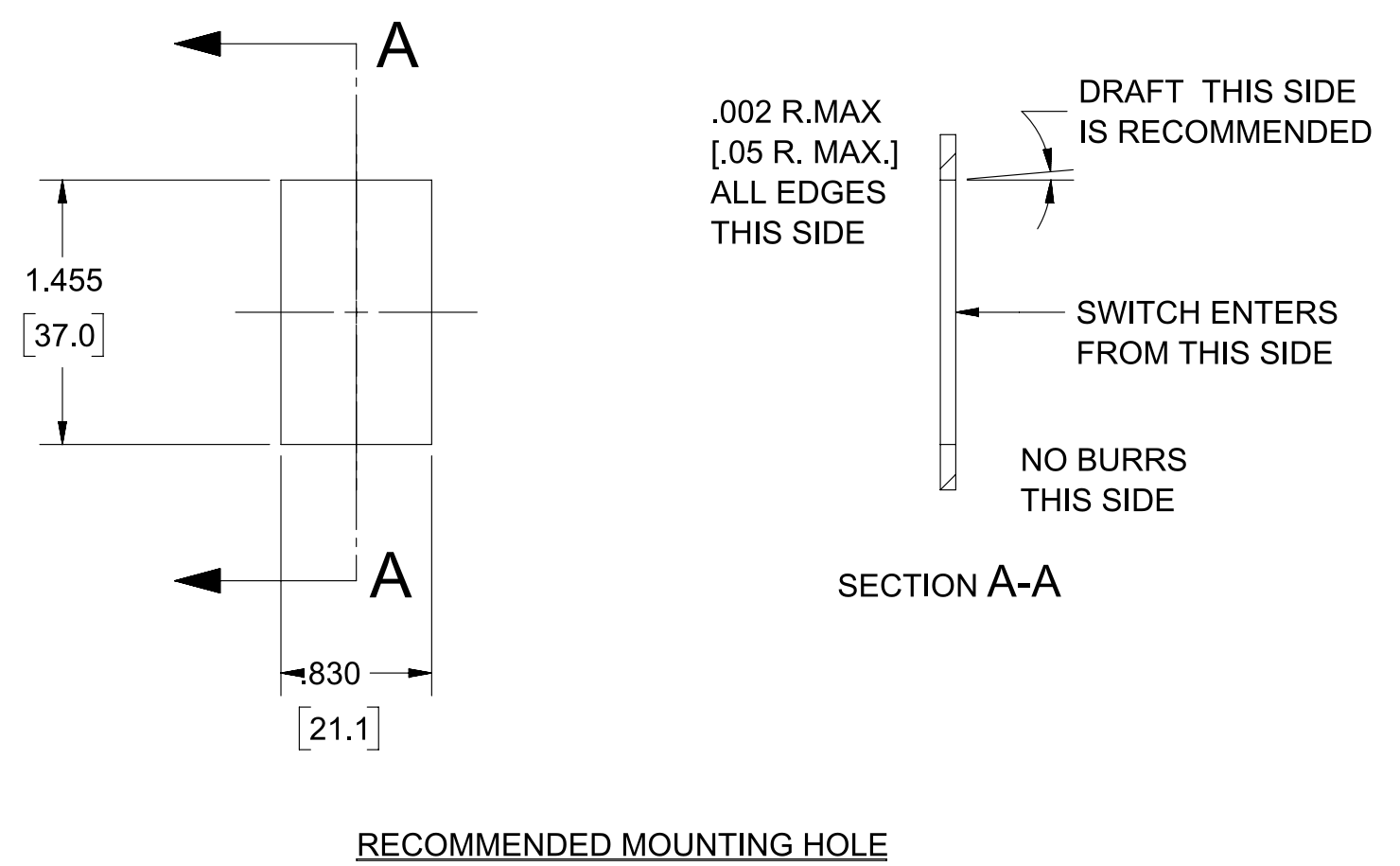
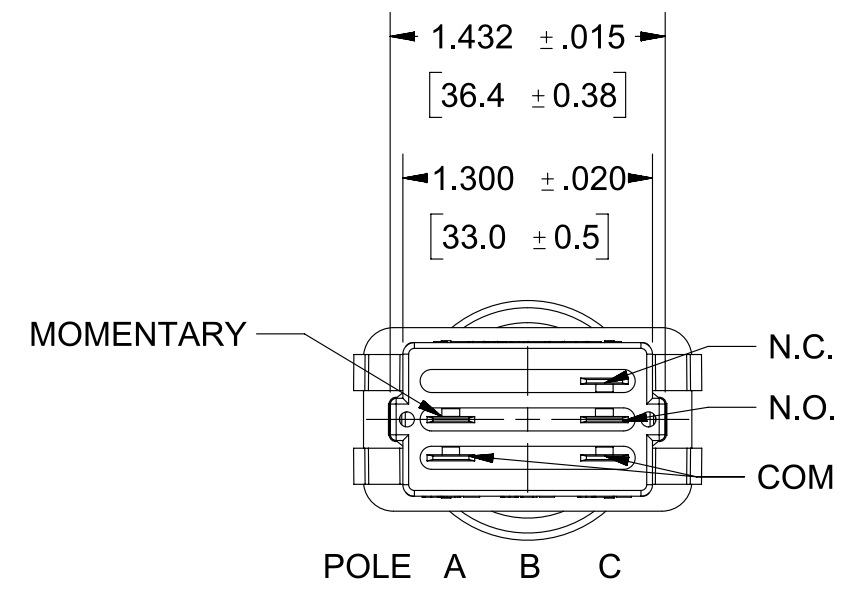
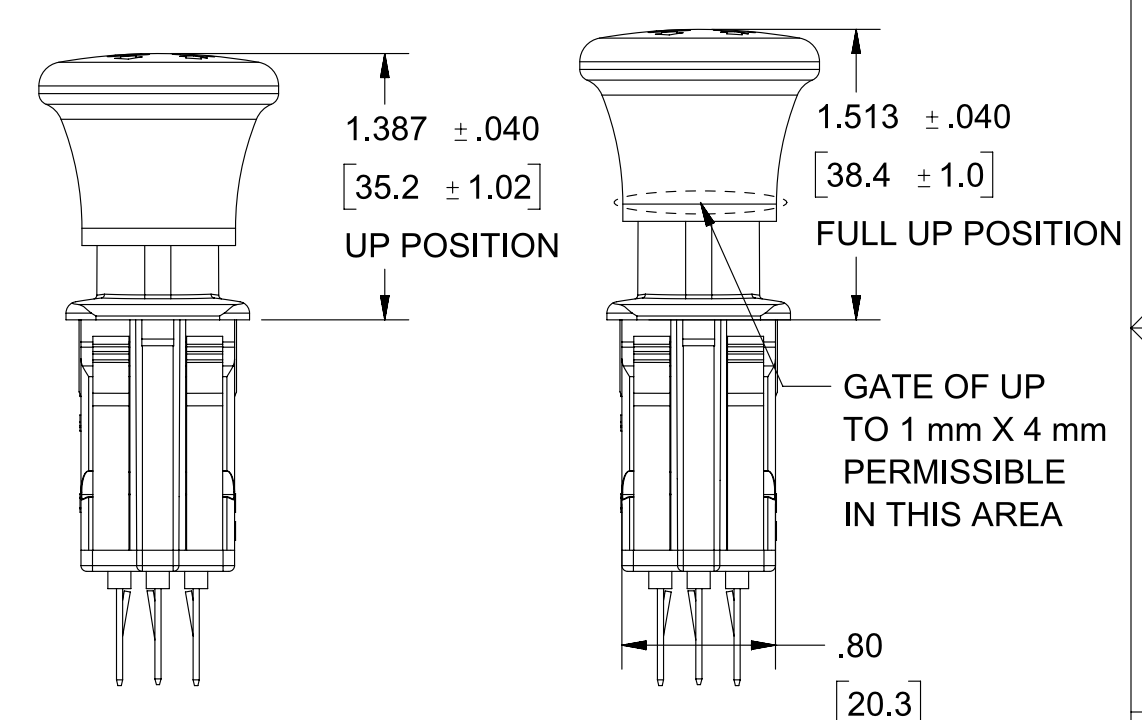
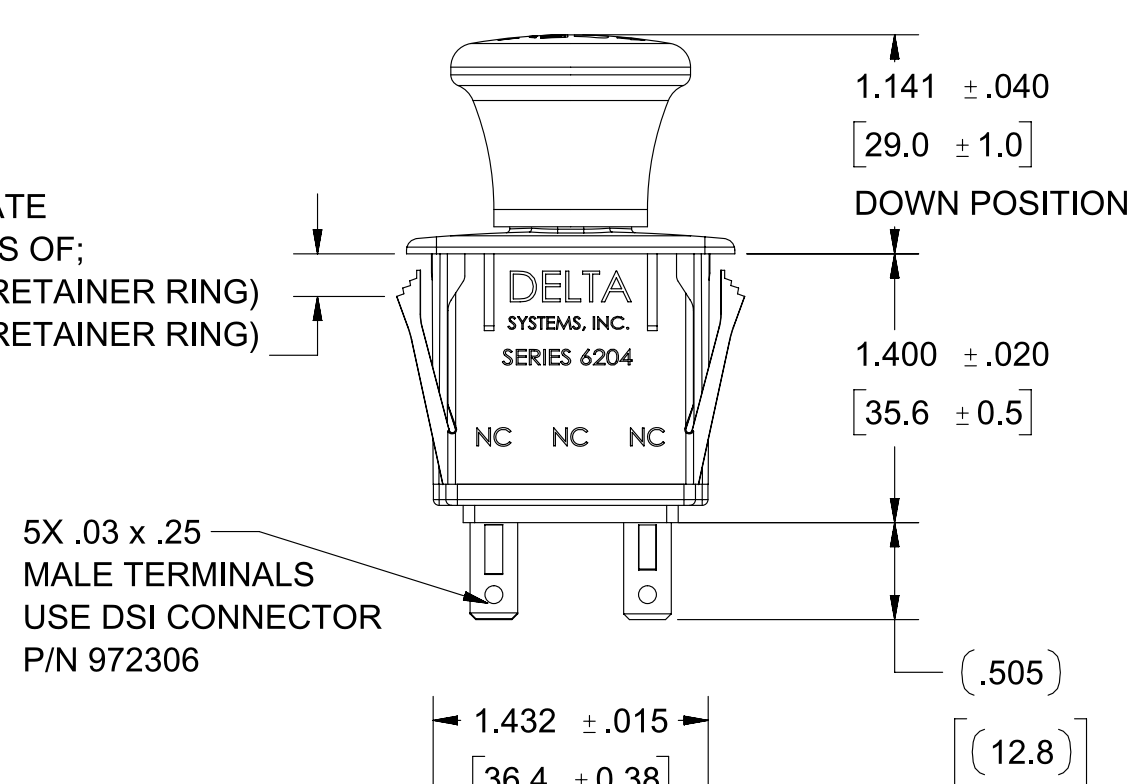

TERMINAL CIRCUIT TABLE			
POSITION	POLE		
	A	B	C
MOMENTARY	CLOSED	N/A	N.O IS CLOSED
DETENT	OPEN	N/A	N.O. IS CLOSED
DOWN	OPEN	N/A	N.C. IS CLOSED

- NOTES
- 1) DIMENSIONS IN BRACKETS [] ARE IN MILLIMETERS.
 - 2) PLASTIC PARTS ARE POLYPROPYLENE; TERMINALS ARE NICKEL OR TIN PLATED BRASS.
 - 3) SWITCH MUST RESIST 40# FORCE WITHOUT PULLING OUT OF PANEL OR DAMAGING SWITCH.
 - 4) KNOB COLOR IS YELLOW, KNOB GRAPHIC COLOR IS BLACK.
 - 5) COLOR OF ALL OTHER COMPONENTS ARE BLACK.
 - 6) BEZEL SURFACE TEXTURED TO MOLD TECH TEXTURE STANDARD MT1055-5.
 - 7) ON (UP) FORCE IS 11.00 ± 3.50 LBS.
OFF (DOWN) FORCE IS 8.50 ± 2.00 LBS.
 - 8) OPERATING FORCES ARE MEASURED AFTER 10 (TEN) CYCLES.
 - 9) DATE CODE INDICATING YEAR, MONTH, & DAY OF MONTH MANUFACTURED APPLIED TO HOUSING.
 - 10) SWITCH FUNCTIONALITY TESTED AFTER ASSEMBLY.
 - 11) AVERAGE ELECTRICAL LIFE IS 40,000 CYCLES WITH A 5A INDUCTIVE LOAD @ 13 VDC
 - 12) THICKNESS INCLUDES PAINT AND/OR ANY OTHER LAYERS APPLIED BETWEEN SWITCH & PANEL.
 - 13) INTERPRET THIS DRAWING IN ACCORDANCE WITH ASME Y14.5-2009
 - 14) MUST BE IN COMPLIANCE WITH DIRECTIVE 2011/65/EU OF THE EUROPEAN PARLIAMENT AND THE COUNCIL OF 8 JUNE 2011 ON THE RESTRICTION OF THE USE OF CERTAIN HAZARDOUS SUBSTANCES IN ELECTRICAL AND ELECTRONIC EQUIPMENT (ROHS DIRECTIVE)

PROPRIETARY & CONFIDENTIAL THE INFORMATION CONTAINED IN THIS DRAWING IS THE SOLE PROPERTY OF DELTA SYSTEMS. ANY REPRODUCTION IN PART OR AS A WHOLE WITHOUT THE WRITTEN PERMISSION OF DELTA SYSTEMS IS PROHIBITED.	UNLESS OTHERWISE SPECIFIED DIMENSIONS ARE IN INCHES TOLERANCES ARE: .X ± .1 .XX ± .02 .XXX ± .005 X° ± 1	DRAWN: mschwenning CHECKED: pcolonna APPROVED: ikirbawy MATERIAL: AS NOTED FINISH: AS NOTED DO NOT SCALE DRAWING	DATE: 12-Aug-2015 DATE: 18-Aug-2015 DATE: 20-Aug-2015 PROJECTED VIEWS ARE 3RD ANGLE STATUS: DS4_Design	DELTA SYSTEMS 1734 FROST ROAD STREETSBORO, OHIO 44241 330-626-2811 WWW.DELTASYSTEMSINC.COM TITLE: PTO Switch Assembly APP SIZE: C DWG. NO.: 6274-202_APP SHEET: 1 OF 1 PROJECT NO.: EX0148G REVISION: 0
	DELTA SYSTEMS INC. DOES NOT ASSUME ANY LIABILITY ARISING OUT OF THE MISAPPLICATION OF ANY PRODUCT COMPUTER GENERATED DRAWING - NO MANUAL CHANGES ALLOWED			