

REVISIONS			
REV.	DESCRIPTION	DATE	INIT
0	INITIAL DRAWING RELEASE	12/09/2016	LJM BSW

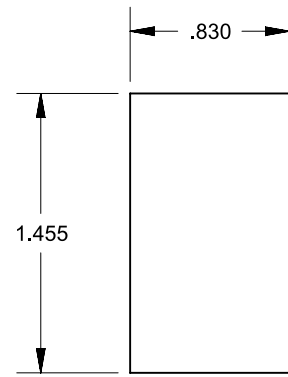

RECOMMENDED MOUNTING HOLE

.002 R. MAX
ALL EDGES
THIS SIDE

DRAFT THIS SIDE
IS RECOMMENDED

SWITCH ENTERS
FROM THIS SIDE

NO BURRS THIS SIDE

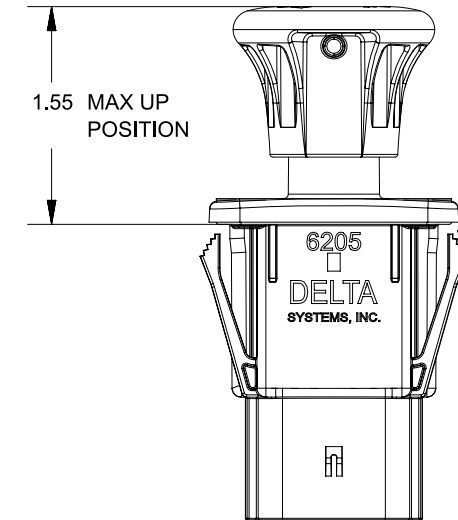
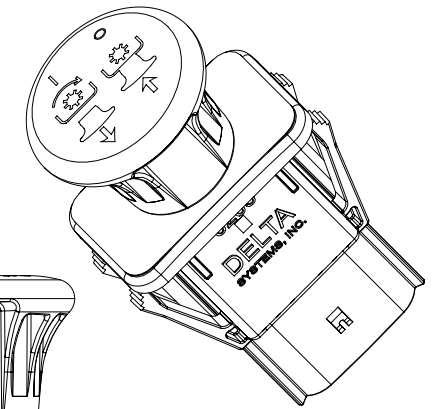
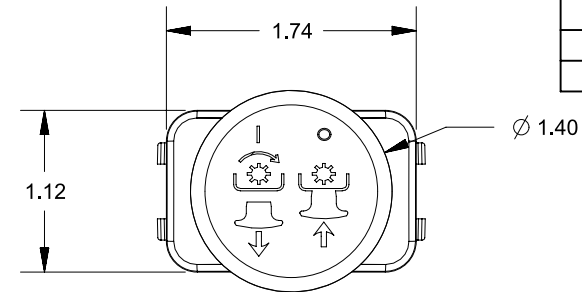

SNAP WINGS DESIGNED TO
ACCOMMODATE PANEL
THICKNESSES OF .060 TO .165
INCLUSIVE OF ANY PAINT,
DECALS, ETC.

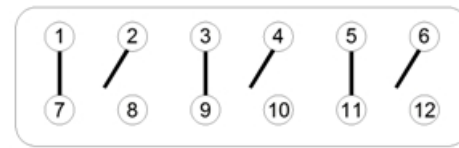
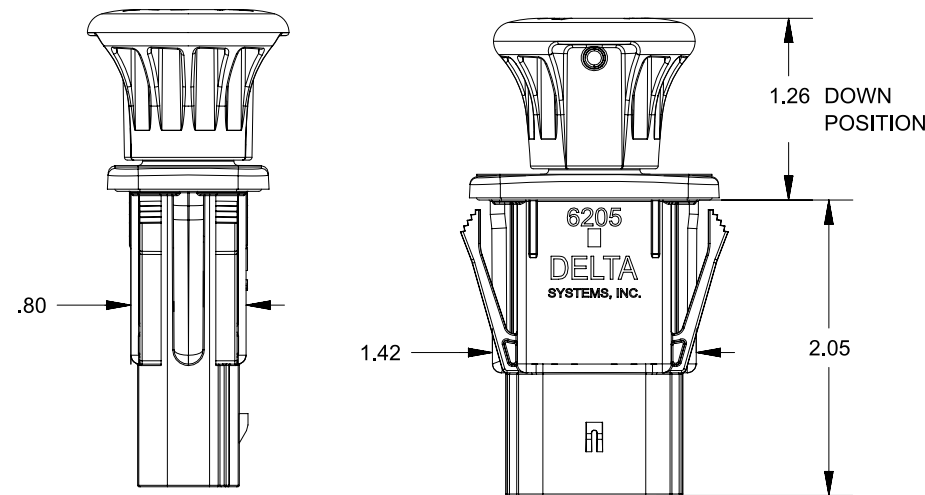

CIRCUITS SHOWN
WITH THE KNOB IN THE
UP POSITION

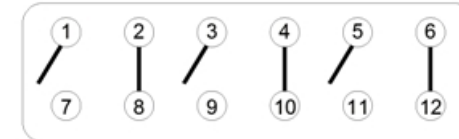

CIRCUITS SHOWN
WITH THE KNOB IN THE
DOWN POSITION

NORMALLY OPEN (NO)
CIRCUITS 1-7, 3-9, 5-11

NORMALLY CLOSED (NC)
CIRCUITS 2-8, 4-10, 6-12

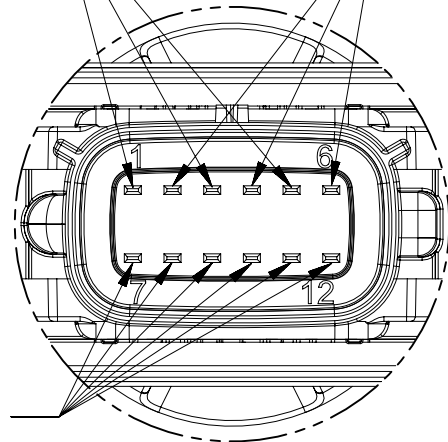

MATING CONNECTOR:
MOLEX MX-150 SEALED CONNECTOR
P/N 33472-1201
MOLEX FEMALE TERMINALS - 33012 SERIES

COMMON TERMINALS (6X)

DETAIL B
SCALE 3:2

NOTES

- 1) MATERIALS:
BODY - POLYPROPYLENE, BLACK
KNOB - POLYPROPYLENE, YELLOW
TERMINALS - BRASS
- 2) KNOB GRAPHIC DESIGN AS SHOWN, PRINTED IN BLACK
- 3) SWITCH MUST WITHSTAND 40 POUNDS OF FORCE WITHOUT PULLING OUT OF PANEL OR DAMAGING SWITCH
- 4) ON (UP) FORCE 13±3 POUNDS ; OFF (DOWN) FORCE 11±3 POUNDS
- 5) OPERATING FORCES ARE DETERMINED AFTER 10 CYCLES
- 6) DELTA SYSTEMS INC. RECOMMENDS THE USE OF 14 AWG WIRE FOR CIRCUIT LOADS OF 8-10 AMPS. USE OF LIGHTER GAGE WIRE MAY RESULT IN PREMATURE FAILURE OF THE SWITCH.
- 7) SWITCH IS ENVIRONMENTALLY SEALED TO MEET IP-67 REQUIREMENTS WITH MATING CONNECTOR INSTALLED
- 8) NO (NORMALLY OPEN) AND NC (NORMALLY CLOSED) CIRCUITS ARE RATED TO 100,000 CYCLES WITH A 10mAMP - 10AMP RESISTIVE LOAD, 12-14 VDC.
- 9) NO (NORMALLY OPEN) CIRCUITS ARE RATED TO 40,000 CYCLES WITH A 10AMP INDUCTIVE LOAD, 12-14 VDC, WITH A SUPPRESSION DIODE ACROSS THE COIL.
- 10) DATE CODE INDICATING YEAR, MONTH AND DAY OF MONTH MANUFACTURED MARKED ON HOUSING PER DELTA MFG SPEC 1640
- 11) SWITCH FUNCTIONALITY TESTED AFTER ASSEMBLY
- 12) MOUNTING PANEL IS SHOWN FOR REFERENCE ONLY AND IS NOT INCLUDED
- 13) INTERPRET THIS DRAWING IN ACCORDANCE WITH ASME Y14.5-2009

PROPRIETARY & CONFIDENTIAL THE INFORMATION CONTAINED IN THIS DRAWING IS THE SOLE PROPERTY OF DELTA SYSTEMS. ANY REPRODUCTION IN PART OR AS A WHOLE WITHOUT THE WRITTEN PERMISSION OF DELTA SYSTEMS IS PROHIBITED. DELTA SYSTEMS INC. DOES NOT ASSUME ANY LIABILITY ARISING OUT OF THE MISAPPLICATION OF ANY PRODUCT	UNLESS OTHERWISE SPECIFIED DIMENSIONS ARE IN INCHES TOLERANCES ARE: .X± .1 .XX± .02 .XXX± .005 X°± 1°	DRAWN Imonaco CHECKED bwetrich APPROVED ikirbawy MATERIAL SEE NOTES FINISH SEE NOTES DO NOT SCALE DRAWING	DATE 17-Mar-2016 DATE 15-Sep-2016 DATE 08-Dec-2016 PROJECTED VIEWS ARE 3RD ANGLE STATUS DS4_Design	DELTA SYSTEMS 1734 FROST ROAD STREETSBORO, OHIO 44241 330-626-2811 WWW.DELTASYSTEMSINC.COM TITLE Platform PTO 6205-131B APP PRINT SIZE B DWG. NO. 6205-131B_APP SCALE NTS SHEET 1 OF 1 PROJECT NO. EX0271 REVISION 0
--	--	---	---	---