

| REVISIONS | | | |
|-----------|-----------------|----------|------|
| REV. | DESCRIPTION | DATE | INIT |
| 0 | INITIAL RELEASE | 09/07/16 | NMP |
| | | | |
| | | | |

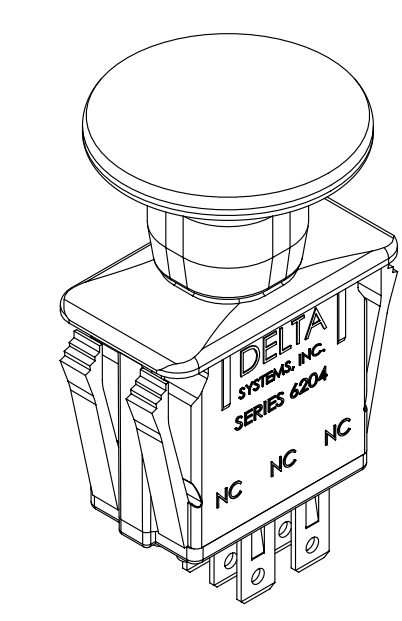

SNAP WINGS TO ACCOMMODATE SPECIFIC PANEL THICKNESSES OF;
 .055 [1.4] MAX. (WITH #972301 RETAINER RING)
 .085 [2.2] MAX. (WITH #972301 RETAINER RING)
 .105 [2.7] MAX.
 .135 [3.4] MAX.
 .165 [4.2] MAX. (NOTE 12)

6X .03 x .25 MALE TERMINALS USE DSI CONNECTOR P/N 972305

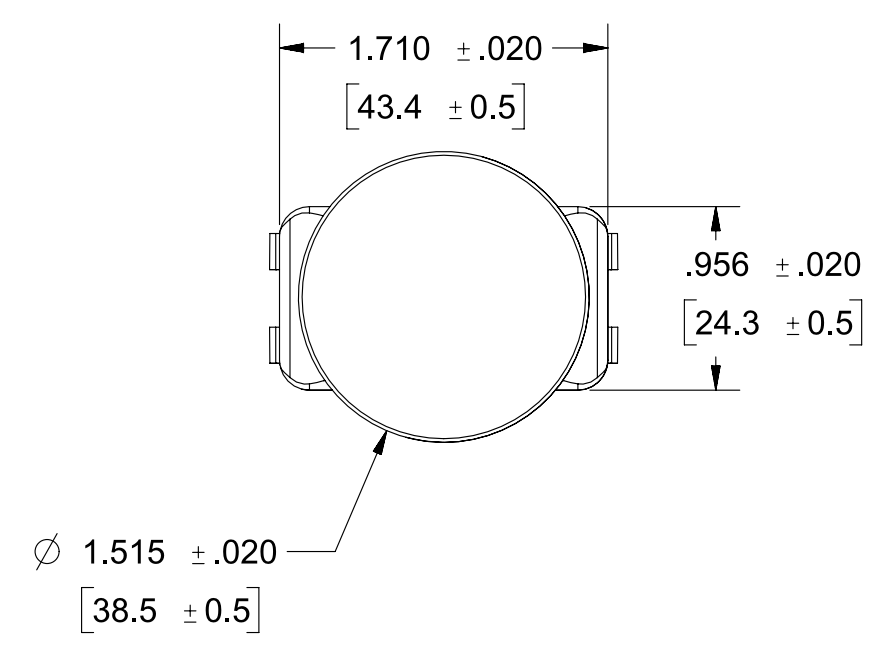
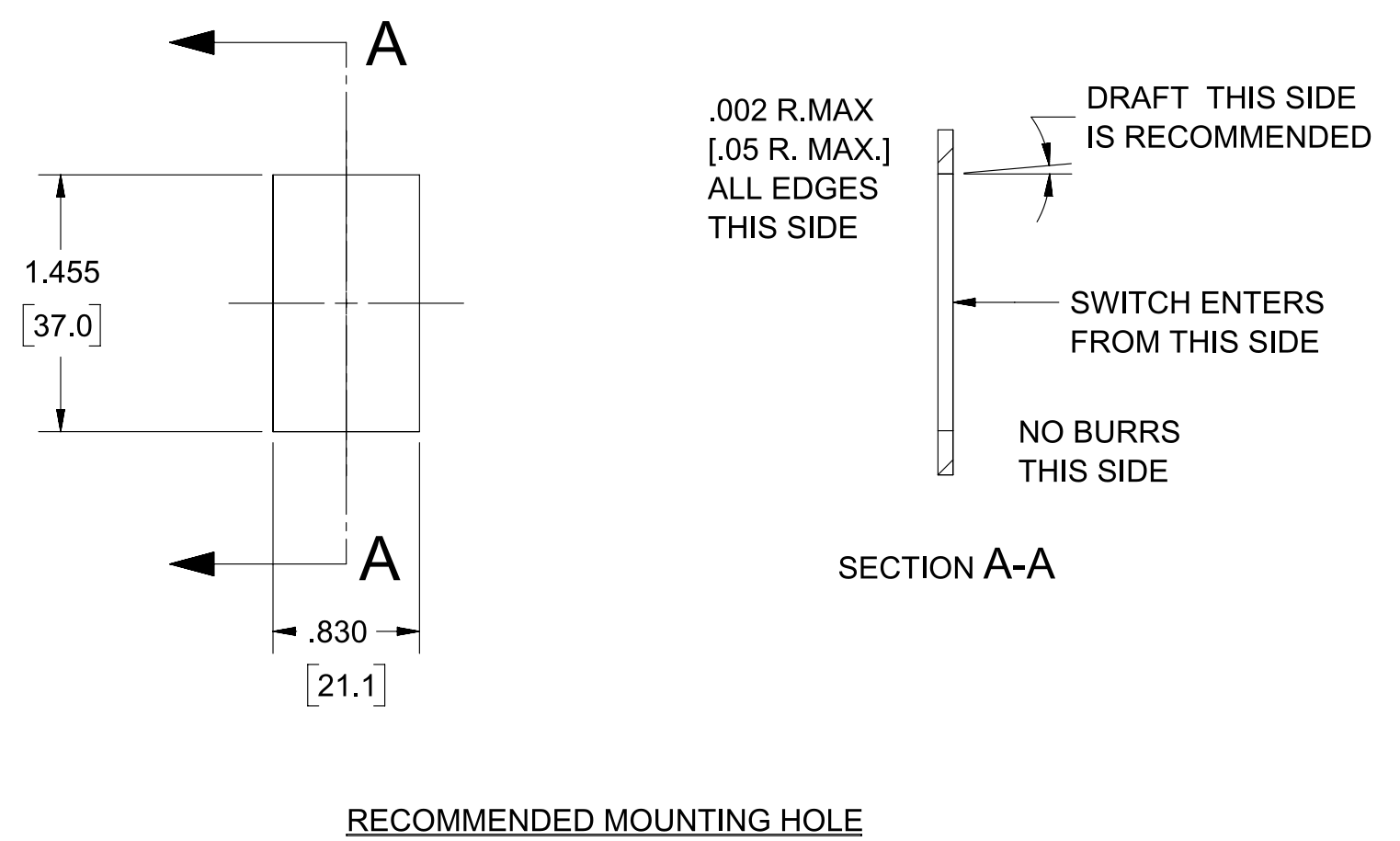
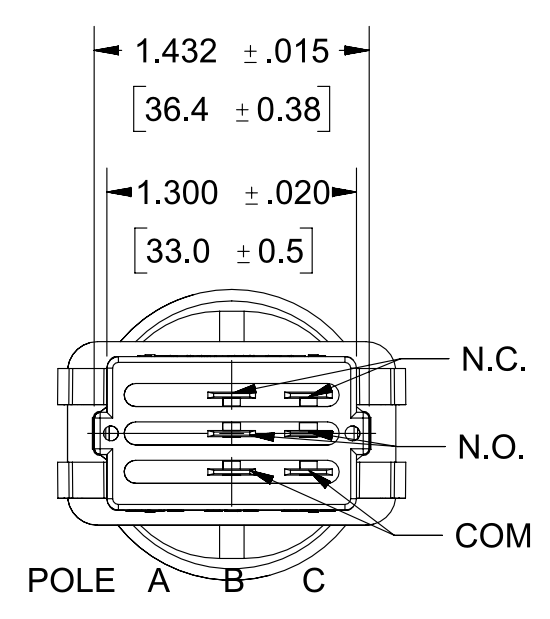
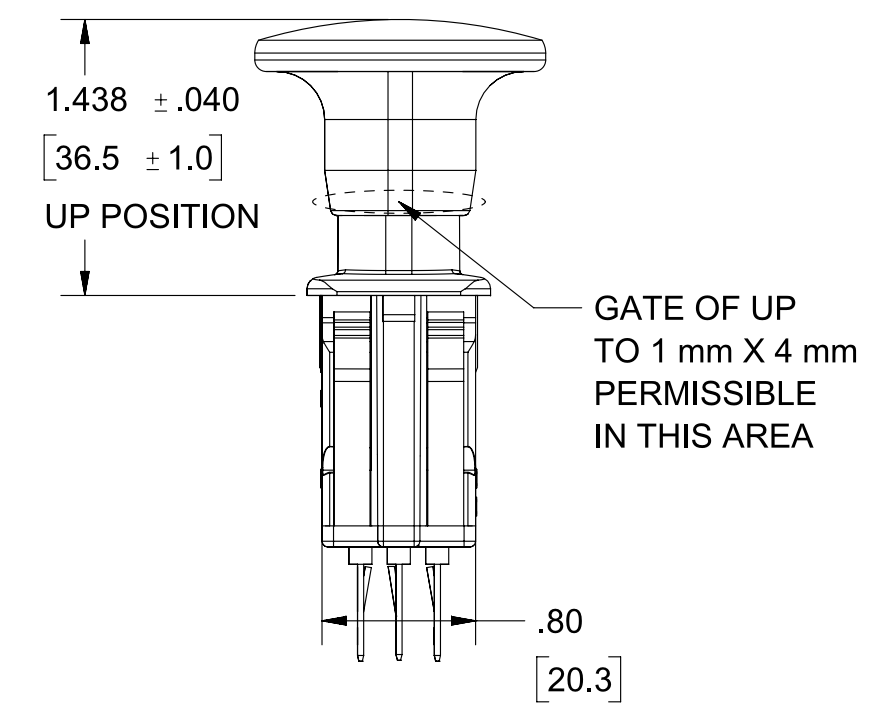
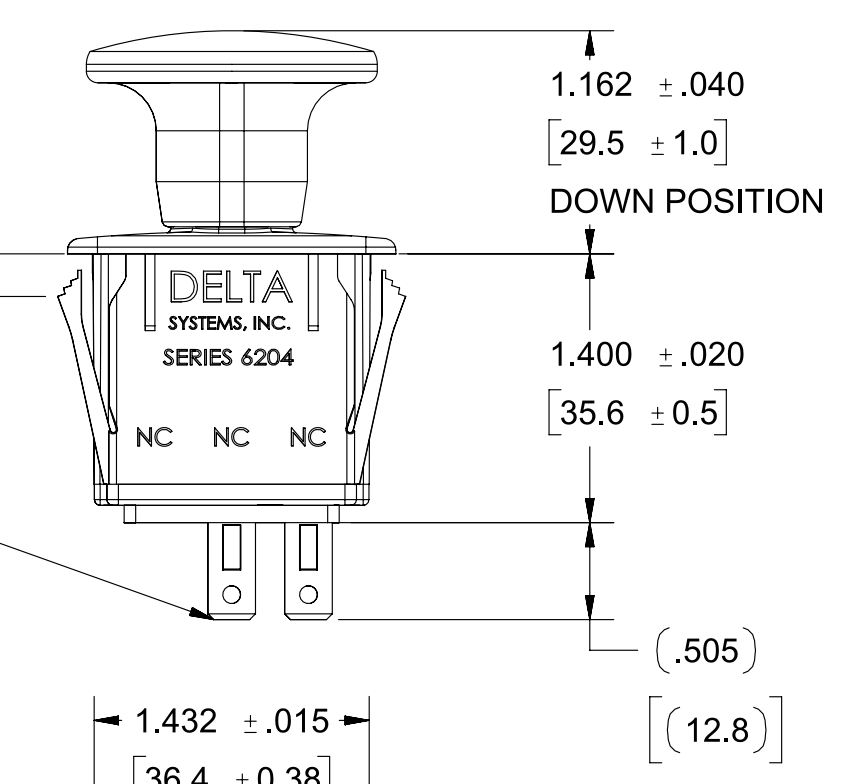

- NOTES**
- 1) DIMENSIONS IN BRACKETS [] ARE IN MILLIMETERS.
 - 2) PLASTIC PARTS ARE POLYPROPYLENE; TERMINALS ARE NICKEL OR TIN PLATED BRASS.
 - 3) SWITCH MUST RESIST 40# FORCE WITHOUT PULLING OUT OF PANEL OR DAMAGING SWITCH.
 - 4) KNOB COLOR IS RED.
 - 5) COLOR OF ALL OTHER COMPONENTS ARE BLACK.
 - 6) BEZEL SURFACE TEXTURED TO MOLD TECH TEXTURE STANDARD MT1055-5.
 - 7) ON (UP) FORCE IS 11.00± 3.50 LBS.
OFF (DOWN) FORCE IS 8.50 ± 2.00 LBS.
 - 8) OPERATING FORCES ARE MEASURED AFTER 10 (TEN) CYCLES.
 - 9) DATE CODE INDICATING YEAR, MONTH, & DAY OF MONTH MANUFACTURED APPLIED TO HOUSING.
 - 10) SWITCH FUNCTIONALITY TESTED AFTER ASSEMBLY.
 - 11) AVERAGE ELECTRICAL LIFE IS 40,000 CYCLES WITH A 5A INDUCTIVE LOAD @ 13 VDC
 - 12) THICKNESS INCLUDES PAINT AND/OR ANY OTHER LAYERS APPLIED BETWEEN SWITCH & PANEL.
 - 13) INTERPRET THIS DRAWING IN ACCORDANCE WITH ASME Y14.5-2009
 - 14) MUST BE IN COMPLIANCE WITH DIRECTIVE 2011/65/EU OF THE EUROPEAN PARLIAMENT AND THE COUNCIL OF 8 JUNE 2011 ON THE RESTRICTION OF THE USE OF CERTAIN HAZARDOUS SUBSTANCES IN ELECTRICAL AND ELECTRONIC EQUIPMENT (ROHS DIRECTIVE)

| | | | |
|---|--|--|---|
| PROPRIETARY & CONFIDENTIAL THE INFORMATION CONTAINED IN THIS DRAWING IS THE SOLE PROPERTY OF DELTA SYSTEMS. ANY REPRODUCTION IN PART OR AS A WHOLE WITHOUT THE WRITTEN PERMISSION OF DELTA SYSTEMS IS PROHIBITED. | UNLESS OTHERWISE SPECIFIED DIMENSIONS ARE IN INCHES TOLERANCES ARE: .X± .1 .XX± .02 .XXX± .005 X°± 1 | DRAWN npurdy DATE 07-Sep-2016 | DELTA SYSTEMS 1734 FROST ROAD STREETSBORO, OHIO 44241 330-626-2811 WWW.DELTASYSTEMSINC.COM |
| | | CHECKED bwetrich DATE 09-Sep-2016 | |
| DELTA SYSTEMS INC. DOES NOT ASSUME ANY LIABILITY ARISING OUT OF THE MISAPPLICATION OF ANY PRODUCT | COMPUTER GENERATED DRAWING - NO MANUAL CHANGES ALLOWED | APPROVED ikirbaw DATE 19-Sep-2016 | PROJECTED VIEWS ARE 3RD ANGLE |
| | | MATERIAL AS NOTED FINISH AS NOTED DO NOT SCALE DRAWING | STATUS DS4_Design SCALE NTS SHEET 1 OF 1 PROJECT NO. CR2093 REVISION 0 |