

REVISIONS			
REV.	DESCRIPTION	DATE	INIT
0	INITIAL RELEASE	08/12/15	MJS

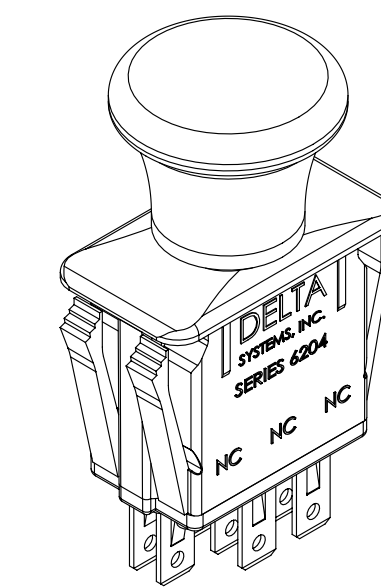

SNAP WINGS TO ACCOMMODATE SPECIFIC PANEL THICKNESSES OF;  
 .055 [1.4] MAX. (WITH #972301 RETAINER RING)  
 .085 [2.2] MAX. (WITH #972301 RETAINER RING)  
 .105 [2.7] MAX.  
 .135 [3.4] MAX.  
 .165 [4.2] MAX.  
 (NOTE 12)

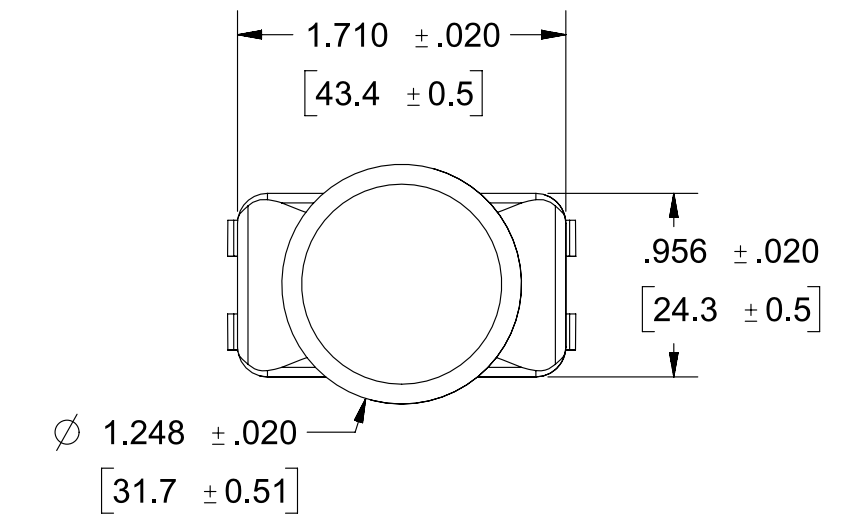
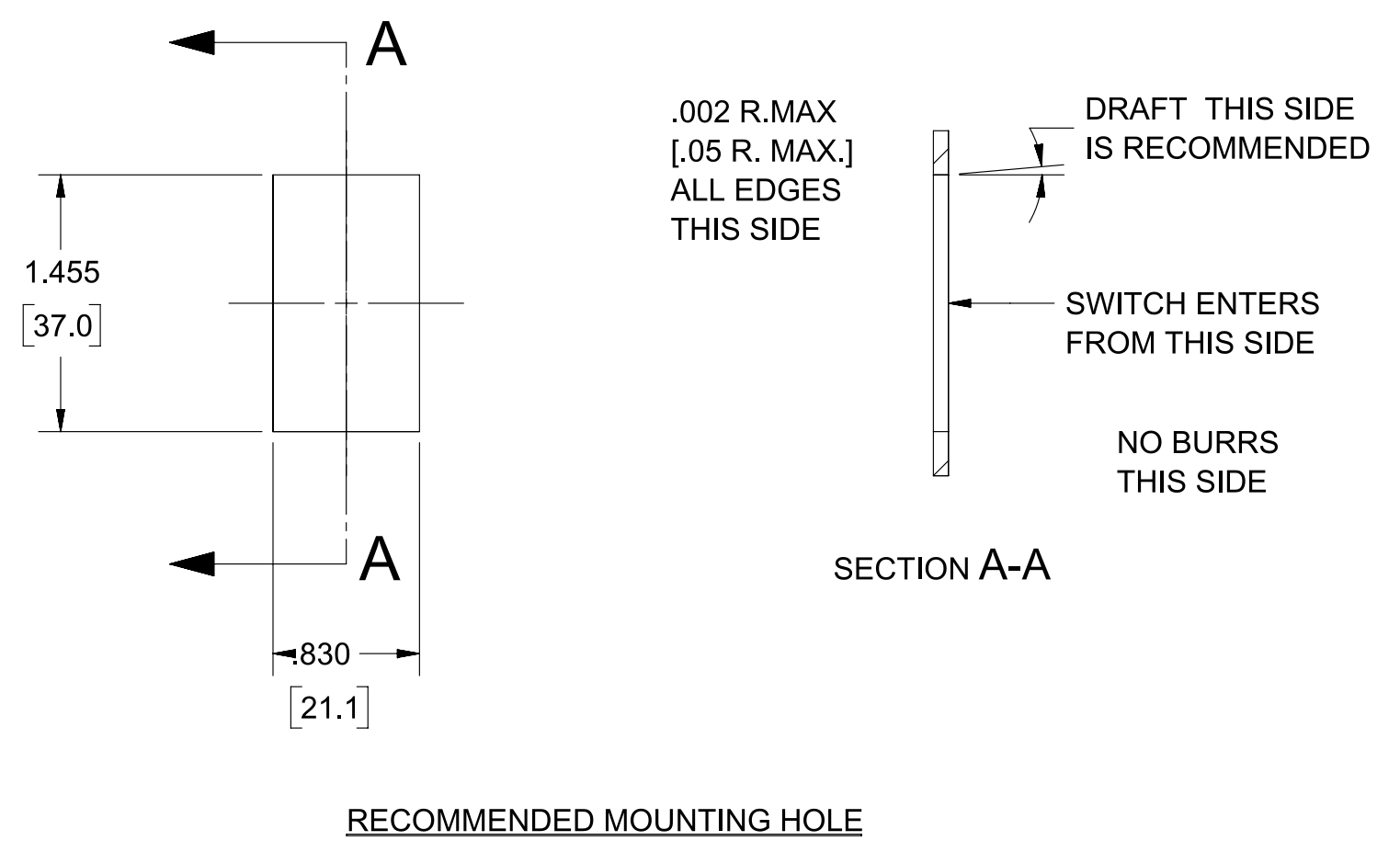
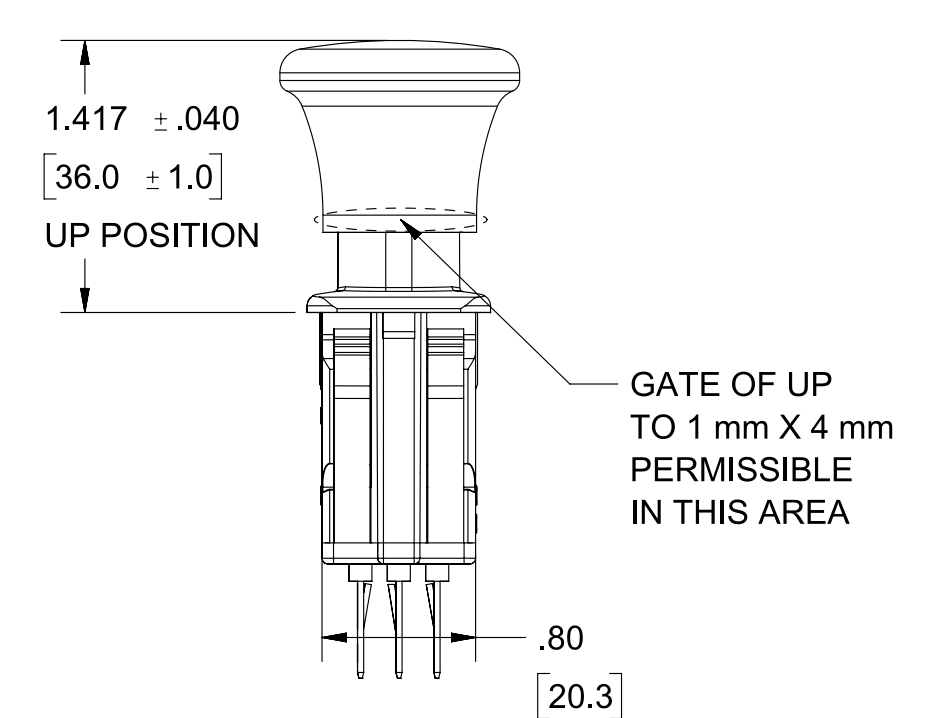
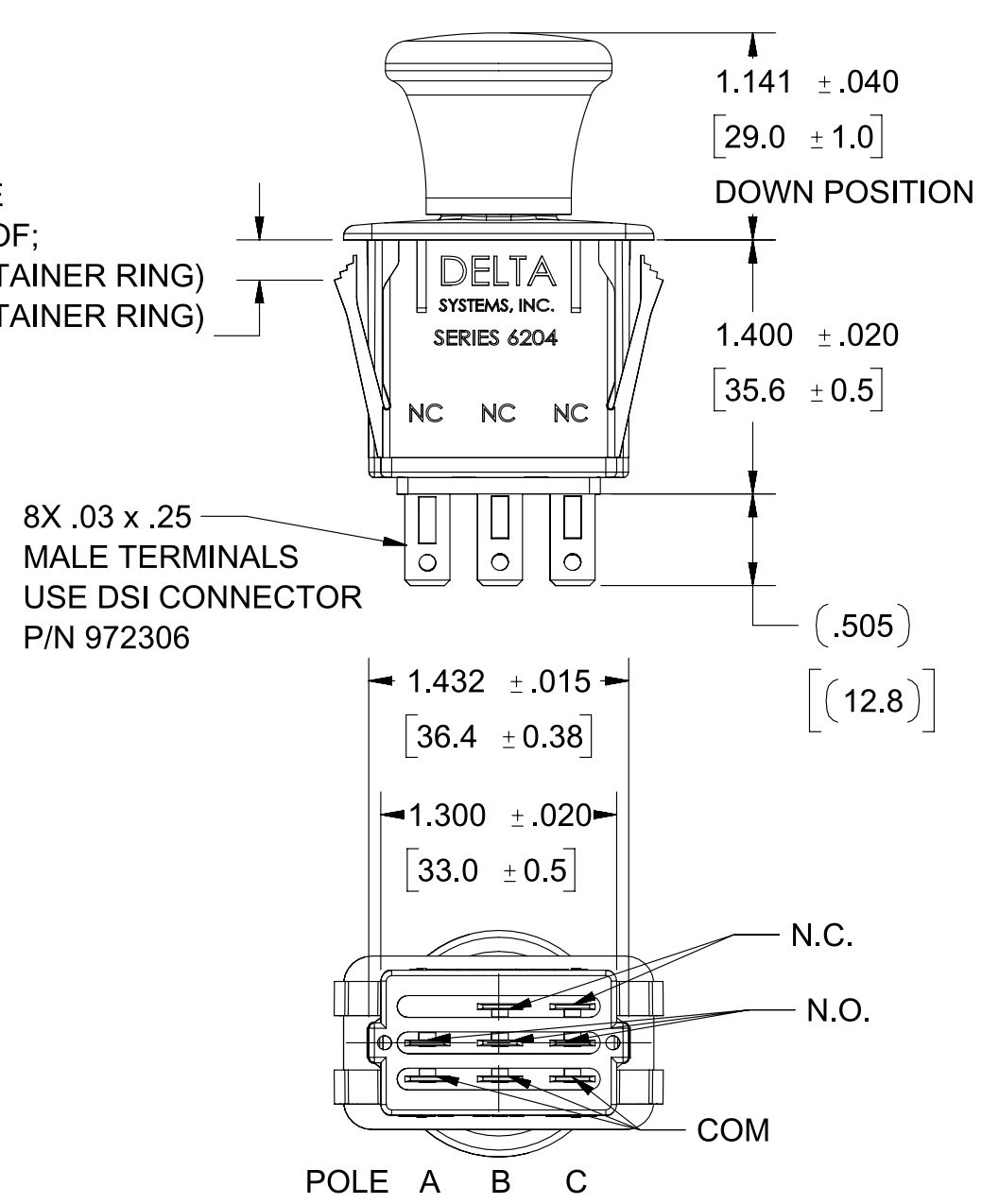

- NOTES**
- 1) DIMENSIONS IN BRACKETS [ ] ARE IN MILLIMETERS.
  - 2) PLASTIC PARTS ARE POLYPROPYLENE; TERMINALS ARE NICKEL OR TIN PLATED BRASS.
  - 3) SWITCH MUST RESIST 40# FORCE WITHOUT PULLING OUT OF PANEL OR DAMAGING SWITCH.
  - 4) KNOB COLOR IS RED.
  - 5) COLOR OF ALL OTHER COMPONENTS ARE BLACK.
  - 6) BEZEL SURFACE TEXTURED TO MOLD TECH TEXTURE STANDARD MT1055-5.
  - 7) ON (UP) FORCE IS 11.00± 3.50 LBS.  
OFF (DOWN) FORCE IS 8.50 ± 2.00 LBS.
  - 8) OPERATING FORCES ARE MEASURED AFTER 10 (TEN) CYCLES.
  - 9) DATE CODE INDICATING YEAR, MONTH, & DAY OF MONTH MANUFACTURED APPLIED TO HOUSING.
  - 10) SWITCH FUNCTIONALITY TESTED AFTER ASSEMBLY.
  - 11) AVERAGE ELECTRICAL LIFE IS 40,000 CYCLES WITH A 5A INDUCTIVE LOAD @ 13 VDC
  - 12) THICKNESS INCLUDES PAINT AND/OR ANY OTHER LAYERS APPLIED BETWEEN SWITCH & PANEL.
  - 13) INTERPRET THIS DRAWING IN ACCORDANCE WITH ASME Y14.5-2009
  - 14) MUST BE IN COMPLIANCE WITH DIRECTIVE 2011/65/EU OF THE EUROPEAN PARLIAMENT AND THE COUNCIL OF 8 JUNE 2011 ON THE RESTRICTION OF THE USE OF CERTAIN HAZARDOUS SUBSTANCES IN ELECTRICAL AND ELECTRONIC EQUIPMENT (ROHS DIRECTIVE)

PROPRIETARY & CONFIDENTIAL THE INFORMATION CONTAINED IN THIS DRAWING IS THE SOLE PROPERTY OF DELTA SYSTEMS. ANY REPRODUCTION IN PART OR AS A WHOLE WITHOUT THE WRITTEN PERMISSION OF DELTA SYSTEMS IS PROHIBITED. DELTA SYSTEMS INC. DOES NOT ASSUME ANY LIABILITY ARISING OUT OF THE MISAPPLICATION OF ANY PRODUCT	UNLESS OTHERWISE SPECIFIED DIMENSIONS ARE IN INCHES TOLERANCES ARE: .X ± .1 .XX ± .02 .XXX ± .005 X° ± 1	DRAWN: mschwenning CHECKED: pcolonna APPROVED: ikirbaw MATERIAL: AS NOTED FINISH: AS NOTED DO NOT SCALE DRAWING	DATE: 12-Aug-2015 DATE: 14-Aug-2015 DATE: 19-Aug-2015 PROJECTED VIEWS ARE 3RD ANGLE STATUS: DS4_Concept	<b>DELTA SYSTEMS</b> 1734 FROST ROAD STREETSBORO, OHIO 44241 330-626-2811 WWW.DELTASYSTEMSINC.COM TITLE: PTO Switch Assembly APP SIZE: C DWG. NO.: 6204-320_APP SHEET: 1 OF 1 PROJECT NO.: EX0148G REVISION: 0
	COMPUTER GENERATED DRAWING - NO MANUAL CHANGES ALLOWED	SCALE: NTS	SHEET: 1 OF 1	PROJECT NO.: EX0148G
	REVISION: 0	SHEET: 1 OF 1	PROJECT NO.: EX0148G	REVISION: 0
	SHEET: 1 OF 1	PROJECT NO.: EX0148G	REVISION: 0	REVISION: 0