

REVISIONS			
REV.	DESCRIPTION	DATE	INIT
0	INITIAL RELEASE	08/12/15	MJS

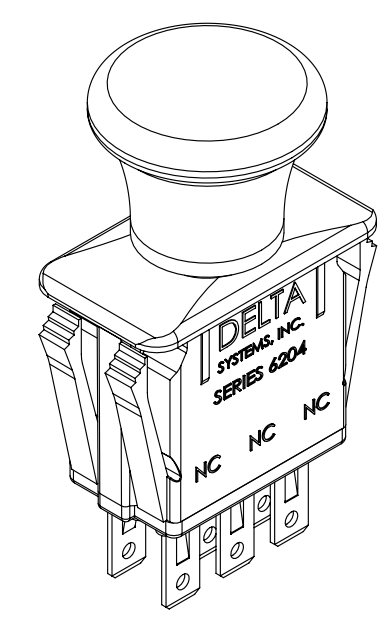
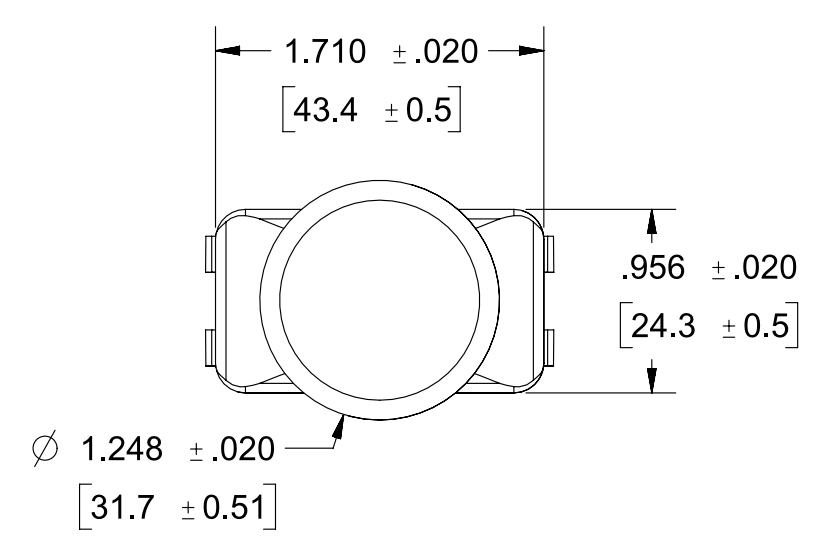
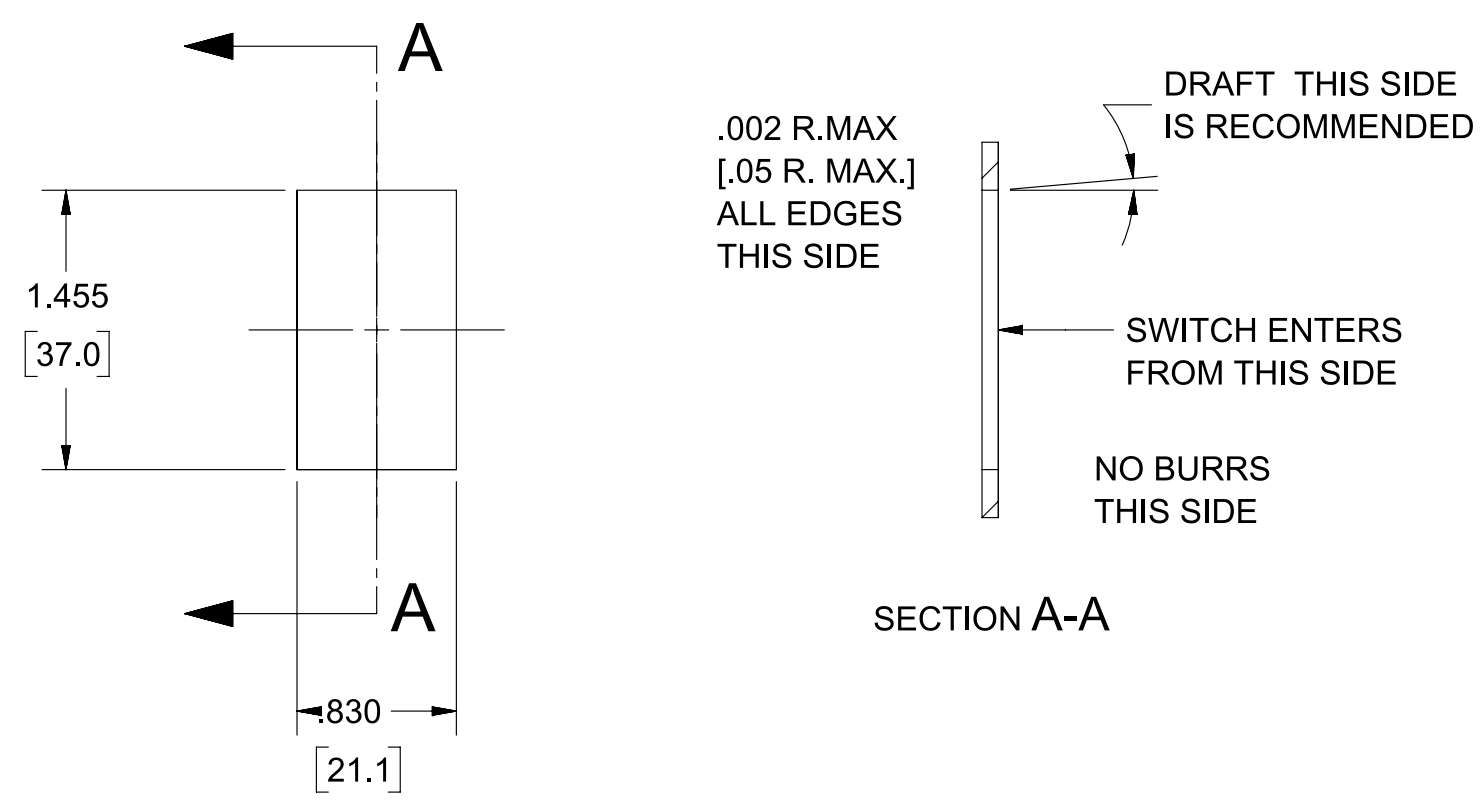

RECOMMENDED MOUNTING HOLE

SNAP WINGS TO ACCOMMODATE SPECIFIC PANEL THICKNESSES OF;  
 .055 [1.4] MAX. (WITH #972301 RETAINER RING)  
 .085 [2.2] MAX. (WITH #972301 RETAINER RING)  
 .105 [2.7] MAX.  
 .135 [3.4] MAX.  
 .165 [4.2] MAX. (NOTE 12)

8X .03 x .25 MALE TERMINALS  
 USE DSI CONNECTOR  
 P/N 972305

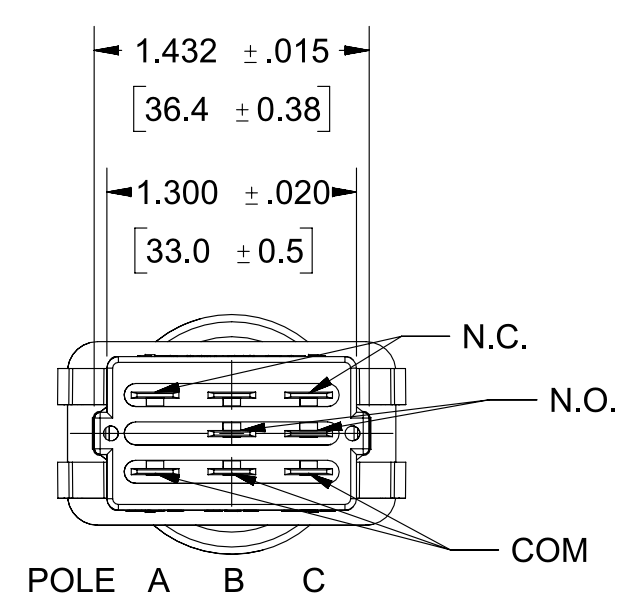
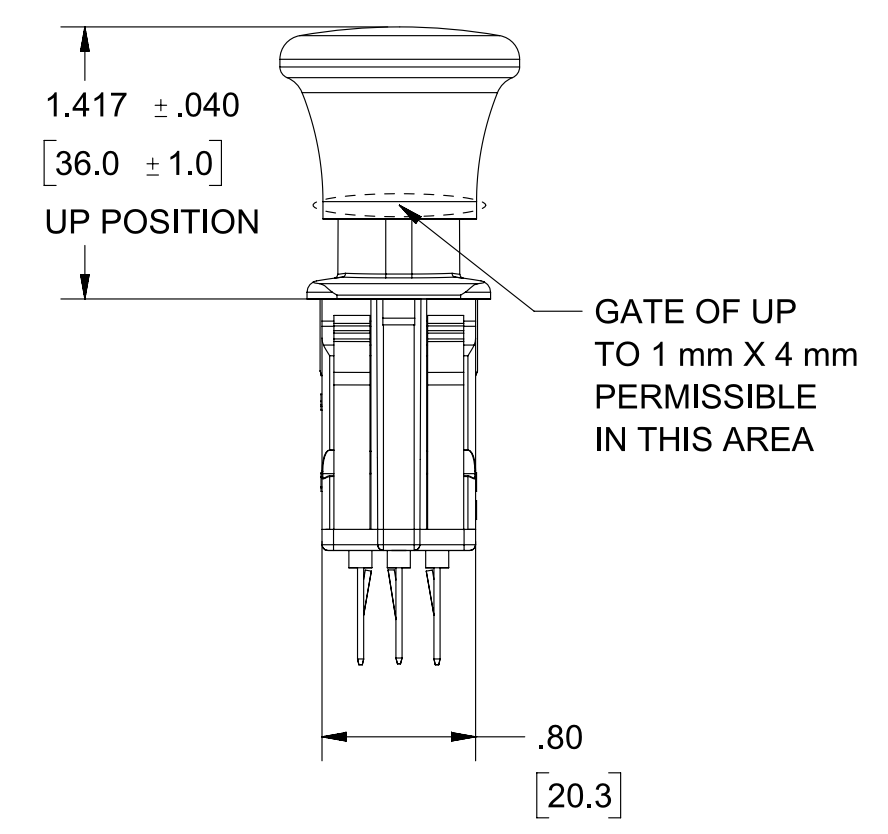
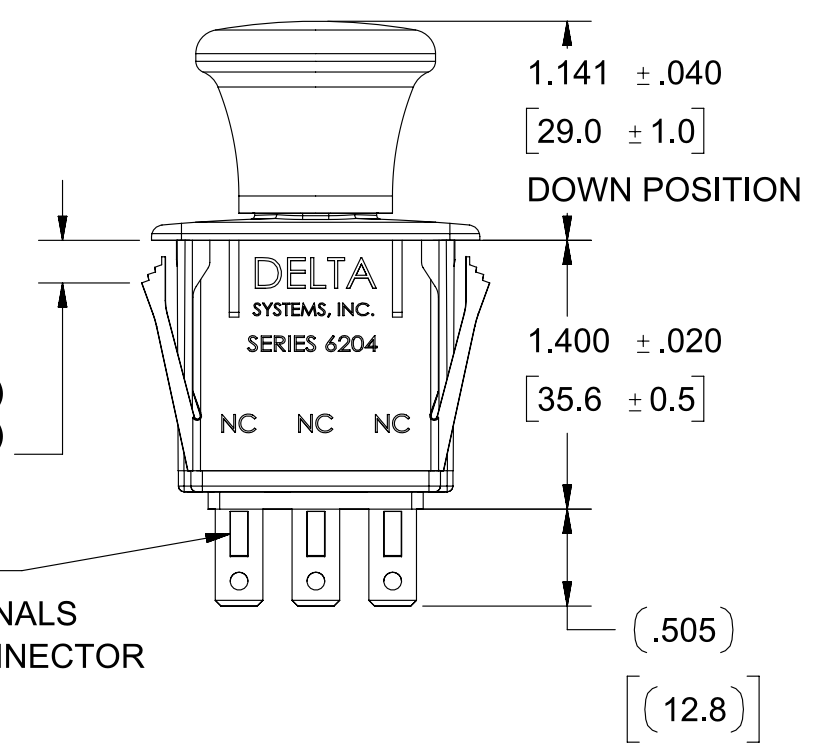

- NOTES**
- 1) DIMENSIONS IN BRACKETS [ ] ARE IN MILLIMETERS.
  - 2) PLASTIC PARTS ARE POLYPROPYLENE; TERMINALS ARE NICKEL OR TIN PLATED BRASS.
  - 3) SWITCH MUST RESIST 40# FORCE WITHOUT PULLING OUT OF PANEL OR DAMAGING SWITCH.
  - 4) KNOB COLOR IS RED.
  - 5) COLOR OF ALL OTHER COMPONENTS ARE BLACK.
  - 6) BEZEL SURFACE TEXTURED TO MOLD TECH TEXTURE STANDARD MT1055-5.
  - 7) ON (UP) FORCE IS 11.00± 3.50 LBS.  
OFF (DOWN) FORCE IS 8.50 ± 2.00 LBS.
  - 8) OPERATING FORCES ARE MEASURED AFTER 10 (TEN) CYCLES.
  - 9) DATE CODE INDICATING YEAR, MONTH, & DAY OF MONTH MANUFACTURED APPLIED TO HOUSING.
  - 10) SWITCH FUNCTIONALITY TESTED AFTER ASSEMBLY.
  - 11) AVERAGE ELECTRICAL LIFE IS 40,000 CYCLES WITH A 5A INDUCTIVE LOAD @ 13 VDC
  - 12) THICKNESS INCLUDES PAINT AND/OR ANY OTHER LAYERS APPLIED BETWEEN SWITCH & PANEL.
  - 13) INTERPRET THIS DRAWING IN ACCORDANCE WITH ASME Y14.5-2009
  - 14) MUST BE IN COMPLIANCE WITH DIRECTIVE 2011/65/EU OF THE EUROPEAN PARLIAMENT AND THE COUNCIL OF 8 JUNE 2011 ON THE RESTRICTION OF THE USE OF CERTAIN HAZARDOUS SUBSTANCES IN ELECTRICAL AND ELECTRONIC EQUIPMENT (ROHS DIRECTIVE)

PROPRIETARY & CONFIDENTIAL THE INFORMATION CONTAINED IN THIS DRAWING IS THE SOLE PROPERTY OF DELTA SYSTEMS. ANY REPRODUCTION IN PART OR AS A WHOLE WITHOUT THE WRITTEN PERMISSION OF DELTA SYSTEMS IS PROHIBITED.	UNLESS OTHERWISE SPECIFIED DIMENSIONS ARE IN INCHES TOLERANCES ARE: .X± .1 .XX± .02 .XXX± .005 X°± 1	DRAWN mschwenning	DATE 12-Aug-2015	1734 FROST ROAD STREETSBORO, OHIO 44241 330-626-2811 WWW.DELTASYSTEMSINC.COM
		CHECKED pcolonna	DATE 14-Aug-2015	
DELTA SYSTEMS INC. DOES NOT ASSUME ANY LIABILITY ARISING OUT OF THE MISAPPLICATION OF ANY PRODUCT	COMPUTER GENERATED DRAWING - NO MANUAL CHANGES ALLOWED	APPROVED ikirbawy	DATE 20-Aug-2015	TITLE PTO Switch Assembly APP
		MATERIAL AS NOTED	FINISH AS NOTED	PROJECTED VIEWS ARE 3RD ANGLE
DO NOT SCALE DRAWING		STATUS DS4_Design		SCALE NTS
		SHEET 1 OF 1	PROJECT NO. 6204-353_APP	REVISION 0