

REVISIONS			
REV.	DESCRIPTION	DATE	INIT
0	INITIAL RELEASE	08/12/15	MJS

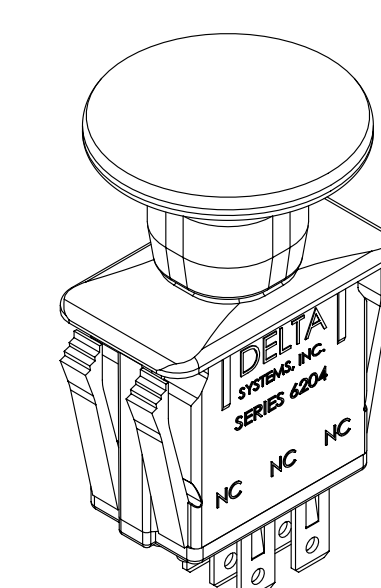

SNAP WINGS TO ACCOMMODATE SPECIFIC PANEL THICKNESSES OF;
 .055 [1.4] MAX. (WITH #972301 RETAINER RING)
 .085 [2.2] MAX. (WITH #972301 RETAINER RING)
 .105 [2.7] MAX.
 .135 [3.4] MAX.
 .165 [4.2] MAX.
 (NOTE 12)

6X .03 x .25 MALE TERMINALS
 USE DSI CONNECTOR
 P/N 972305

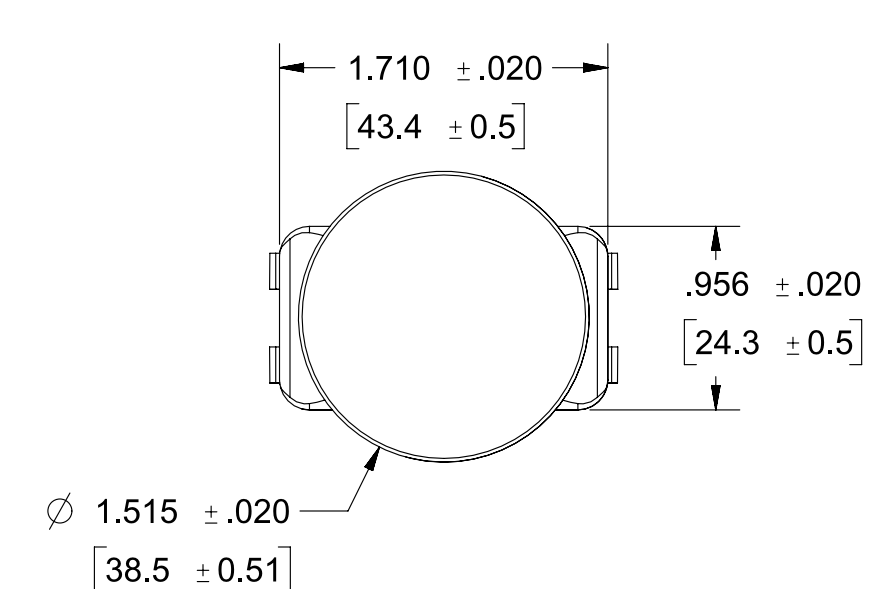
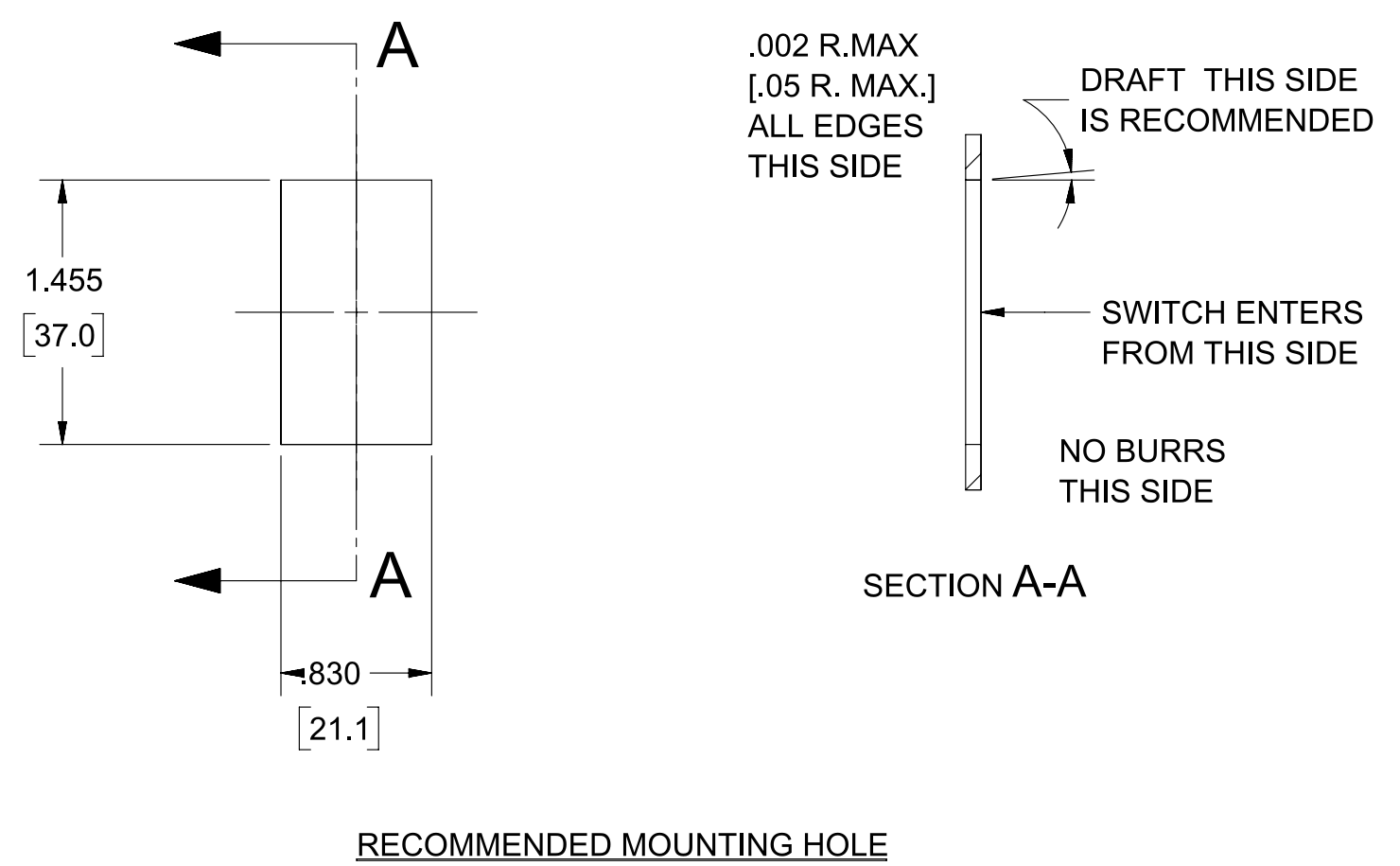
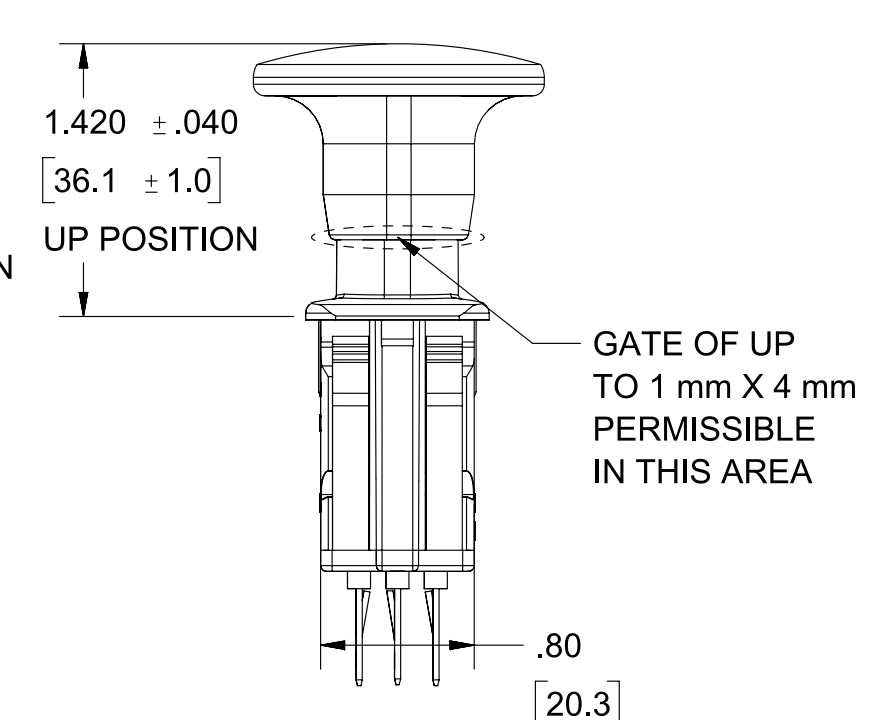
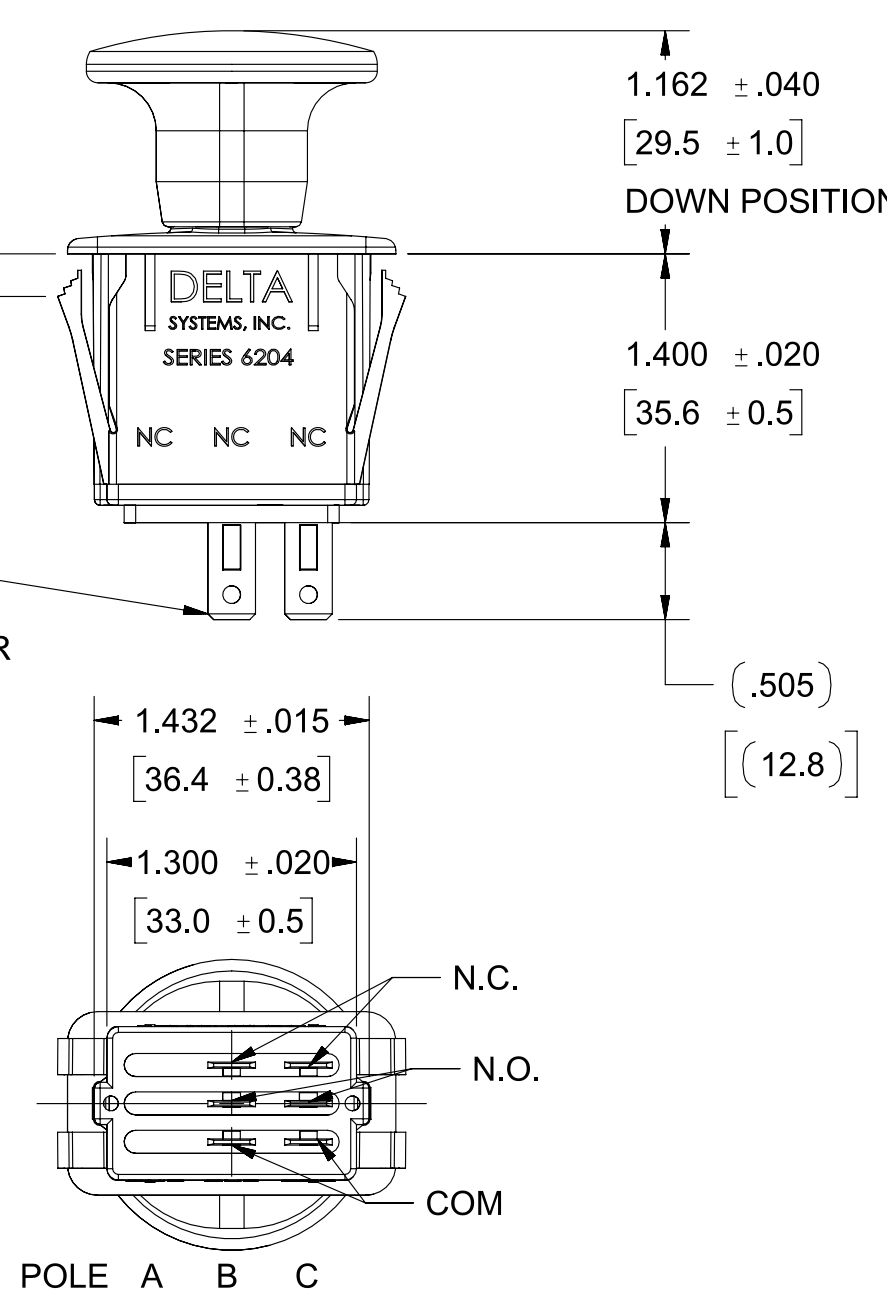

- NOTES
- 1) DIMENSIONS IN BRACKETS [] ARE IN MILLIMETERS.
 - 2) PLASTIC PARTS ARE POLYPROPYLENE; TERMINALS ARE NICKEL OR TIN PLATED BRASS.
 - 3) SWITCH MUST RESIST 40# FORCE WITHOUT PULLING OUT OF PANEL OR DAMAGING SWITCH.
 - 4) KNOB COLOR IS BLACK.
 - 5) COLOR OF ALL OTHER COMPONENTS ARE BLACK.
 - 6) BEZEL SURFACE TEXTURED TO MOLD TECH TEXTURE STANDARD MT1055-5.
 - 7) ON (UP) FORCE IS 11.00 ± 3.50 LBS.
OFF (DOWN) FORCE IS 8.50 ± 2.00 LBS.
 - 8) OPERATING FORCES ARE MEASURED AFTER 10 (TEN) CYCLES.
 - 9) DATE CODE INDICATING YEAR, MONTH, & DAY OF MONTH MANUFACTURED APPLIED TO HOUSING.
 - 10) SWITCH FUNCTIONALITY TESTED AFTER ASSEMBLY.
 - 11) AVERAGE ELECTRICAL LIFE IS 40,000 CYCLES WITH A 5A INDUCTIVE LOAD @ 13 VDC
 - 12) THICKNESS INCLUDES PAINT AND/OR ANY OTHER LAYERS APPLIED BETWEEN SWITCH & PANEL.
 - 13) INTERPRET THIS DRAWING IN ACCORDANCE WITH ASME Y14.5-2009
 - 14) MUST BE IN COMPLIANCE WITH DIRECTIVE 2011/65/EU OF THE EUROPEAN PARLIAMENT AND THE COUNCIL OF 8 JUNE 2011 ON THE RESTRICTION OF THE USE OF CERTAIN HAZARDOUS SUBSTANCES IN ELECTRICAL AND ELECTRONIC EQUIPMENT (ROHS DIRECTIVE)

PROPRIETARY & CONFIDENTIAL THE INFORMATION CONTAINED IN THIS DRAWING IS THE SOLE PROPERTY OF DELTA SYSTEMS. ANY REPRODUCTION IN PART OR AS A WHOLE WITHOUT THE WRITTEN PERMISSION OF DELTA SYSTEMS IS PROHIBITED.	UNLESS OTHERWISE SPECIFIED DIMENSIONS ARE IN INCHES TOLERANCES ARE: .X ± .1 .XX ± .02 .XXX ± .005 X° ± 1	DRAWN mschwenning	DATE 12-Aug-2015	1734 FROST ROAD STREETSBORO, OHIO 44241 330-626-2811 WWW.DELTASYSTEMSINC.COM
		CHECKED pcolonna	DATE 14-Aug-2015	
DELTA SYSTEMS INC. DOES NOT ASSUME ANY LIABILITY ARISING OUT OF THE MISAPPLICATION OF ANY PRODUCT	COMPUTER GENERATED DRAWING - NO MANUAL CHANGES ALLOWED	APPROVED ikirbawy	DATE 19-Aug-2015	TITLE PTO Switch Assembly APP
		MATERIAL AS NOTED	FINISH AS NOTED	PROJECTED VIEWS ARE 3RD ANGLE
DO NOT SCALE DRAWING		STATUS DS4_Design		SIZE C
		SCALE NTS	SHEET 1 OF 1	PROJECT NO. EX0148G
				DWG. NO. 6204-208_APP
				REVISION 0