

REVISIONS			
REV.	DESCRIPTION	DATE	INIT
0	INITIAL RELEASE	10/08/14	MJS

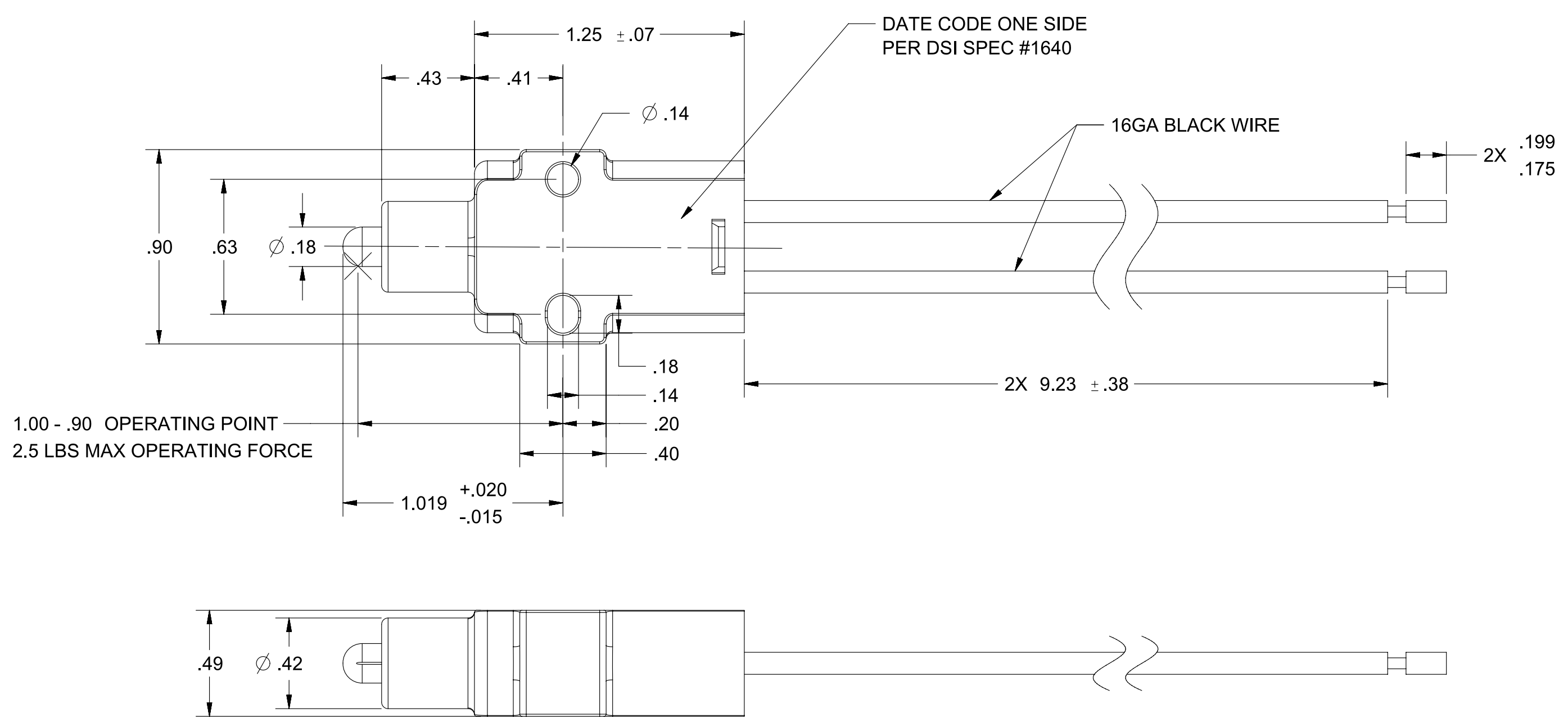

INTERPRET THIS DRAWING IN ACCORDANCE WITH ASME Y14.5-2009

**MATERIAL SPECIFICATION AND NOTES**

1. SWITCH HOUSING IS UV STABLE ACETAL COPOLYMER WITH 12% GLASS FIBER, COLOR: BLACK.
2. SWITCH PLUNGER MATERIAL IS ACETAL COPOLYMER WITH 12% GLASS FIBER, COLOR: BLACK.
3. SWITCH IS DATE CODED ON ONE SIDE OF HOUSING PER DELTA DATE CODE SPECIFICATION #1640.
4. PLUNGER SEALING O-RING LUBRICANT IS NYE UNIFLOR #8132.
5. WIRE TO BE 16 GA. (37/32) 80°C, PVC INSULATION. CABLE LAY-UP MAY CONSIST OF MORE STRANDS OF FINER WIRE PROVIDED TOTAL CROSS SECTIONAL AREA IS NO LARGER.
6. LEAD WIRES CONFORM TO SAE J1128 AND SAE J378.

**ELECTRICAL CONTACT DATA**

7. ELECTRICAL CONTACTS ARE SILVER ALLOY PLATED.
8. TYPICAL LOAD 3 AMPS AT 12-14 VDC RESISTIVE.
9. INITIAL VOLTAGE DROP IS 100 mV MAX.

**DURABILITY REQUIREMENT**

10. 100,000 CYCLES WITH A 3 AMP RESISTIVE LOAD @ 12-14 VDC.
11. SWITCH AND SEALED LEADS WITHSTAND 10" HG VACUUM WHEN SUBMERGED IN WATER PER DSI "SALT WATER TEST" BEFORE AND AFTER CYCLE TESTING.
12. NO INGRESS OF EXTERNAL CONTAMINANTS ALLOWED.

**OPERATING ENVIRONMENT - USAGE INFORMATION, NO TESTING REQUIRED**

13. STORAGE TEMPERATURE: -30°C TO 85°C
14. OPERATING TEMPERATURE -8°C TO 85°C
15. EXPOSURE TO FRESH AND SALT WATER.

PROPRIETARY & CONFIDENTIAL THE INFORMATION CONTAINED IN THIS DRAWING IS THE SOLE PROPERTY OF DELTA SYSTEMS. ANY REPRODUCTION IN PART OR AS A WHOLE WITHOUT THE WRITTEN PERMISSION OF DELTA SYSTEMS IS PROHIBITED.	UNLESS OTHERWISE SPECIFIED DIMENSIONS ARE IN INCHES TOLERANCES ARE: .X ± .1 .XX ± .02 .XXX ± .005 X° ± 1	DRAWN mschwenning CHECKED bkirkman APPROVED ikirbawy MATERIAL N/A FINISH N/A DO NOT SCALE DRAWING	DATE 08-Oct-2014 DATE 18-Dec-2014 DATE 16-Jun-2015 PROJECTED VIEWS ARE 3RD ANGLE STATUS DS4_Design	<b>DELTA SYSTEMS</b> 1734 FROST ROAD STREETSBORO, OHIO 44241 330-626-2811 WWW.DELTASYSTEMSINC.COM TITLE Universal Switch N.O. Application SIZE C DWG. NO. 7081-21_APP SCALE NTS SHEET 1 OF 1 PROJECT NO. EX0257 REVISION 0
	DELTA SYSTEMS INC. DOES NOT ASSUME ANY LIABILITY ARISING OUT OF THE MISAPPLICATION OF ANY PRODUCT	COMPUTER GENERATED DRAWING - NO MANUAL CHANGES ALLOWED	STATUS DS4_Design	
	PROJECTED VIEWS ARE 3RD ANGLE	FINISH N/A	DATE 16-Jun-2015	
	UNLESS OTHERWISE SPECIFIED DIMENSIONS ARE IN INCHES TOLERANCES ARE:	DRAWN mschwenning	DATE 08-Oct-2014	