

8

7

6

5

4

3

2

1

REVISIONS

REV.	DESCRIPTION	DATE	INIT
D	RE-DESIGNED KEY, CR616	09/21/94	TW
E	REV DIM. ADD TOL., CR975	04/21/97	TW
F	MAT'L STEEL TO STAINLESS, CR1535	04/07/04	MEL
G	ADD NP-CR STEEL TO PRINT, CR1586	12/20/04	JLM
H	CONTOURED RE-DESIGN, CR1630	06/01/06	MEL
J	REDREW, .22 WAS .23	11/21/12	IDK
12	2.22 WAS 2.20	09/13/13	IDK

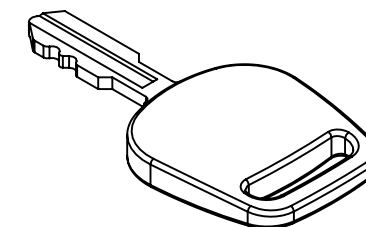
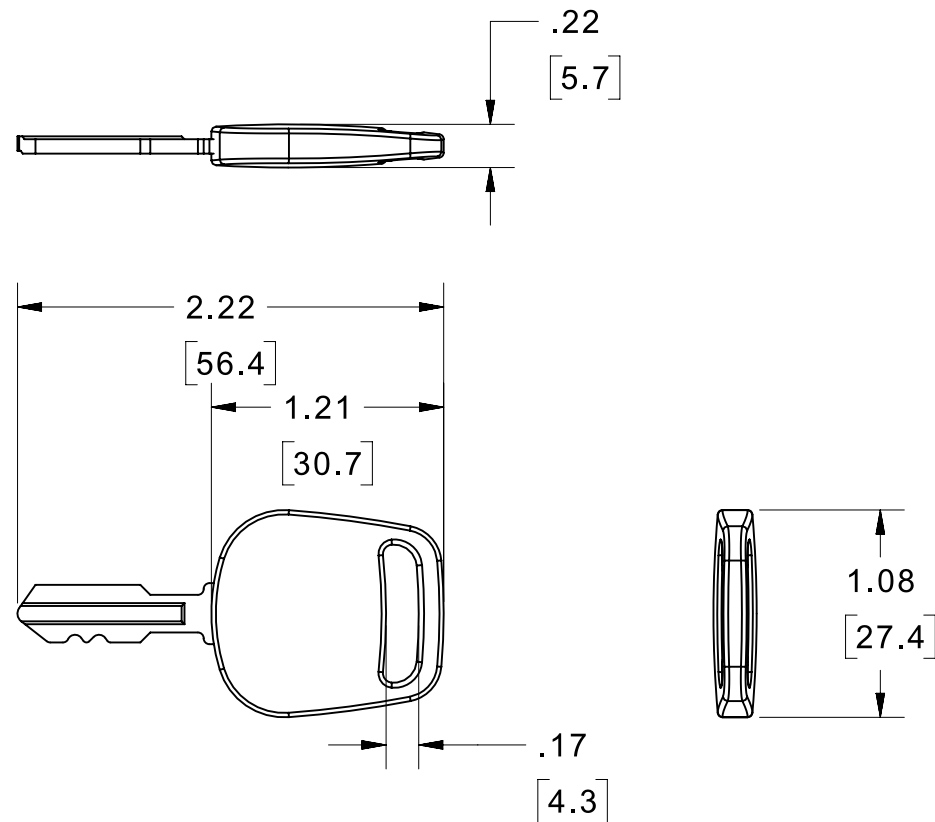

ISOMETRIC VIEW

NOTES

- 1) KEY FITS DELTA 6850 AND 69XX SERIES KEY SWITCHES
- 2) MATERIAL
OVERMOLD - BLACK POLYPROPYLENE
KEY - NICKEL PLATED STEEL OR STAINLESS STEEL
- 3) MOLDED HEAD IS TEXTURED PER MT-11020 OR EQUIVALENT
- 4) DIMENSIONS IN BRACKETS ARE IN MILLIMETERS

PROPRIETARY & CONFIDENTIAL THE INFORMATION CONTAINED IN THIS DRAWING IS THE SOLE PROPERTY OF DELTA SYSTEMS. ANY REPRODUCTION IN PART OR AS A WHOLE WITHOUT THE WRITTEN PERMISSION OF DELTA SYSTEMS IS PROHIBITED.	UNLESS OTHERWISE SPECIFIED DIMENSIONS ARE IN INCHES TOLERANCES ARE: .X± .1 .XX± .02 .XXX± .005 X°± 1°	DRAWN drk	DATE 13-Jul-1992	DELTA SYSTEMS 1734 FROST ROAD STREETSBORO, OHIO 44241 330-626-2811 WWW.DELTASYSTEMSINC.COM		
		CHECKED tw	DATE 13-Jul-1992			
APPROVED ikirbawy	DATE 11-Dec-2012	MATERIAL SEE NOTES	PROJECTED VIEWS ARE 3RD ANGLE 		TITLE Key, Overmolded, Standard	
DELTA SYSTEMS INC. DOES NOT ASSUME ANY LIABILITY ARISING OUT OF THE MISAPPLICATION OF ANY PRODUCT	COMPUTER GENERATED DRAWING - NO MANUAL CHANGES ALLOWED	FINISH SEE NOTES	DO NOT SCALE DRAWING	STATUS DS4_Design	SIZE B	DWG. NO. 688P-STD_APP
		SCALE NTS	SHEET 1 OF 1	PROJECT NO. EX338	REVISION 12	

8

7

6

5

4

3

2

1